



Powering Business Worldwide

Introduction

220 Series Piston Pump

Eaton's new 220 Series piston pump signifies a step change in the generation of hydraulic power. Utilizing the latest developments in hydraulic pump technology, the 220 is specifically designed for low flow, high pressure applications. It is currently available in 28cc (1.71 cubic inches) displacement with future plans to include the development of 18cc and 45cc displacements in the family. With a wide range of pump controls, the 220 is rated for 280 bar and 3,000 rpm making it the ideal pump for an array of different mobile and stationary applications. Capable of generating over 52.6 horsepower (39.2kW), the 28cc 220 provides more power in a smaller, compact package. This increased power generation allows equipment manufacturers to design more productive, powerful vehicles with a longer life.

The new 220 design also incorporates many new advances in product reliability. Once equipment is in the field, pump failures can prove to be extremely expensive and costly downtime results. The 220 blends Eaton's long tradition in providing quality pumps with the latest design and technology methods to ensure long lasting product reliability. The result is a very simple design, consisting of almost 25% fewer parts than previously designed pumps.

Eaton employs a unique system of tools and processes, known as Eaton Business System, to ensure quality development and delivery of the 220 product. These tools and process include such known methods as Design for Six Sigma, Lean Manufacturing and ISO certification. Our global network of manufacturing locations and distribution partners enables the 220 to be flexibly configured and delivered throughout the world. Eaton's vision is to be our customer's preferred global supplier of fluid power components. By incorporating the latest advancements in hydraulic pump design and manufacturing, the 220 delivers greater value in terms of power and reliability.



Typical Applications

- Construction
 - Wheel Loaders
 - Backhoe Loaders
- Agriculture
 - Tractors
 - Harvesting Equipment
- Truck and Bus
 - Salt and Sand Spreaders
 - Vacuum Trucks
- Material Handling
 - Aerial Work Platforms
- Other Mobile
 - Fan Drives

Features and Benefits

- Lower maintenance costs due to longer pump life and simpler design
- More engine compartment flexibility due to compact size
- Increased hydraulic power per displacement
- Greater fuel savings due to reduced weight and high efficiency design
- Low Noise resulting from low weight and optimized valve plate

Table of Contents

Model Codes	4
Specifications and Performance	5
Control Options	
Load Sense and Pressure Compensator	6
Pressure Compensator	7
Performance	
AEC028	8
Pump Installation	
B-mount – Rear-ported	11
B-mount – Side-ported	12
Control Installation	
Load Sense and Pressure Compensator	13
Pressure Compensator	14
External Manual Stroke Adjustment	15
Input Shaft Options	16
Installation and Start-up	17

Model Codes

220 Mobile Piston Pump

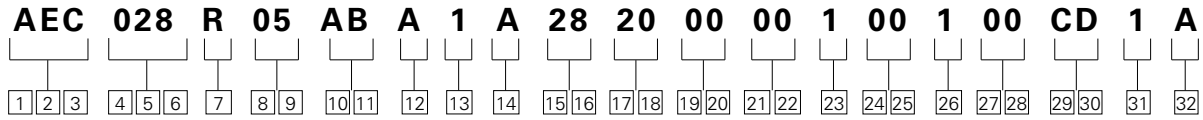

1 2 3 Pump Series
AEC – 220 Series Open Circuit Piston Pump

4 5 6 Pump Displacement
028 – 28.0 cm³/r [1.71 in³/r]

7 Input Shaft Rotation
R – Right Hand
L – Left Hand

8 9 Front Mount and Shaft
05 – 2 Bolt B, 22.2 mm (0.88) Dia. Keyed Shaft
09 – 2 Bolt B, 13 Tooth 16/32 Spline
31 – 2 Bolt B, 25.4 mm (1.00 in) Dia Straight Keyed
34 – 2 Bolt C, 15 Tooth 16/32 Spline

10 11 Main Ports Size & Location
AB – Side Ports
 Suction - 1.63" O-Ring
 Pressure - 1.06" O-Ring
AD – Side Ports
 Suction - M42 Metric O-Ring
 Pressure - M27 Metric O-Ring

12 Case Drain Ports
A – #10 SAE O-Ring - Top
B – #10 SAE O-Ring - Bottom
C – M22 x 1.5 O-Ring - Top
D – M22 x 1.5 O-Ring - Bottom

13 Diagnostic Pressure Ports
Not available on thru-drive units
1 – #4 SAE O-Ring Port - Plugged
2 – M12 X 1.5 Metric O-Ring Port - Plugged

14 Controller Type
A – Pressure Flow Compensator With #4 SAE O-Ring Load Sense Port
B – Pressure Flow Compensator With M14 Metric O-Ring Load Sense Port
C – Pressure Compensator Only

15 16 Pressure Compensator Setting (Tolerance on Setting)*
02 – 76 - 83 bar (1100-1200 lbf/in²)
26 – 193 - 203 bar (2850-2950 lbf/in²)
34 – 234 - 241 bar (3400-3500 lbf/in²)
43 – 276 - 283 bar (4000-4100 lbf/in²)

17 18 Flow Compensator Setting (Tolerance on Setting)
00 – No Flow Compensator Setting
14 – 12 - 15 bar (180-220 lbf/in²)
20 – 17 - 20 bar (250-290 lbf/in²)

19 20 Torque Control Setting
00 – No Torque Control

21 22 Control Special Features
00 – No Control Special Features
0A – Bleed Down Orifice

23 Maximum Displacement Option
1 – Standard Displacement (As Given in Code Title)
2 – External Manual Stroke Adjustment

24 25 Auxiliary (Rear) Mount & Output Shaft
00 – No Auxiliary Mounting Features

26 Shaft Seal
1 – Standard Polyacrylate Shaft Seal

27 28 Pump Special Features
00 – No Special Features
AB – Swash Position Sensor

29 30 Paint
00 – No Paint
CD – Blue Primer

31 Identification/Packaging
1 – Standard Eaton Identification Box Packaging

32 Design Level
A – First Design

* Additional Settings Available by Request

Specifications and Performance

General Performance Specifications

		Units	AEC018	AEC028
Displacement		cc/r (in³/r)		28.0 (1.71)
Weight¹		kg (lbm)		16.3 (35.9)
Pressure	Continuous	bar (psi)		280 (4060)
	Intermittent ²			320 (4600)
	Peak ³			350 (5000)
Speed⁴	At 1 bar abs (0 psig)	rpm		3000
	At .85 bar abs (5 in.Hg)			2700
	Max (standby)			3600
	Min			500
Power	Max (theoretical)	kW (hp)		39.2 (52.6)
	Standby			2.1 (2.8)
Torque	Max (theoretical)	Nm (lb-ft)		125 (92)
Bearing Life⁵	At 140 bar (2030 psi)	B10 Hours		129,000
	At 210 bar (3045 psi)			37,800
	At 280 bar (4060 psi)			7,680
Mass Moment of Inertia		Nm-sec² (lb-in-sec²)		

1 Standard SAE B non-through drive.

2 Less than 10% of duty cycle.

3 Momentary system pressure spikes only.

4 Ratings based on Flange ports.

5 Bearing life ratings at rated speed – 1 bar abs (0 psig) inlet.

Will vary based on thrust and side loads.

Inlet Pressure, Case Pressure, and Operating Temperature Requirements

Inlet Pressure			Case Pressure			Operating Temperature		
Rated bar abs (psig)	Minimum bar abs (in. Hg)	Maximum bar abs (psig)	Maximum Continuous bar abs (psig)	Maximum Intermittent bar abs (psig)	Peak bar abs (psig)	Rated °C (°F)	Minimum Temperature °C (°F)	Maximum Intermittent °C (°F)
1.0 (0)	0.85 (5)	4.4 (50)	1.3 (5)	3.1 (30)	6.2 (75)	93 (200)	-25 (-13)	104 (220)

Hydraulic Fluids

Fluid	Recommended Operating Viscosity Range cSt (SUS)	Maximum Continuous cSt (SUS)	Maximum Viscosity at Startup cSt (SUS)	Minimum Viscosity @ Max. Intermittent Temperature of 93°C (200°F) cSt (SUS)	Minimum Intermittent cSt (SUS)
Use antiwear hydraulic oil, or automotive type crankcase oil (designations SC, SD, SE or SF) per SAE J183 FEB80	16 to 40 (80 to 188)	430 (1192)	2100 (9720)	10 (59)	6 (46)

For more information, see Eaton publication 579. For operation on other alternative or environmentally friendly fluids, please contact your Eaton Representative.

Control Options

Load Sense and Pressure Compensator

Load Sense and Pressure Compensator Control

The pump will provide power matching of pump output to system load demand, maximizing efficiency and improving load metering characteristics of any directional control valve installed between the pump and the load.

Load sensing ensures that the pump always provides only the amount of flow needed by the load. At the same time, the pump operating pressure adjusts to the actual load pressure plus a pressure differential required for the control action. When the system is not demanding power, the load sense control will operate in an energy-saving stand-by mode.

Typically, the differential pressure is that between the pressure inlet and service port of a proportionally controlled directional valve, or a load sensing directional control valve. See the model code on page 4 for differential pressure settings for load sensing.

If the load pressure exceeds the system pressure setting, the pressure compensator de-strokes the pump. The load sensing line must be as short as possible and can also be used for remote control or unloading of the pump pressure. For remote control purposes, it is recommended that you contact your Eaton Representative for the correct configuration of the control.

Warning: When adjusting the pressure limiter, install a 0 to 350 bar (0 to 5000 psi) gage in the outlet gage port and limit the pressure setting to the continuous rated pressure for the pump displacement shown on page 6. It is possible to adjust the pressure compensator beyond the rated pressure of the pump. Doing so, may void the warranty of the X20 pump.

Pressure Limit Settings

The pressure compensator uses two springs to cover the full pressure range of the X20 pumps. The high pressure spring covers the range from 140 bar (2050 psi) to 280 bar (4060 psi). The low pressure spring is adjustable from minimum pressure through 140 bar (2050 psi).

Flow Compensator (Load Sense) Settings

There are three springs used to cover the load sense adjustment range of this control.

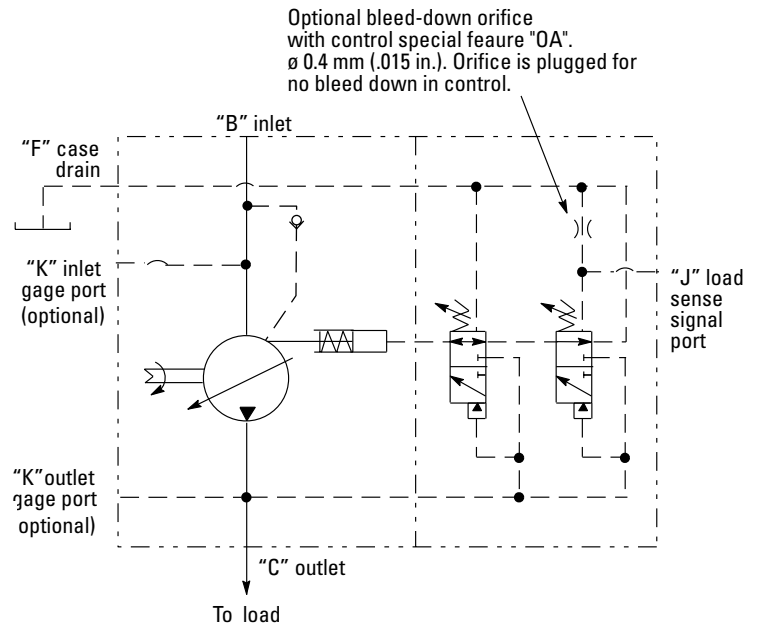

Typical Operating Curve

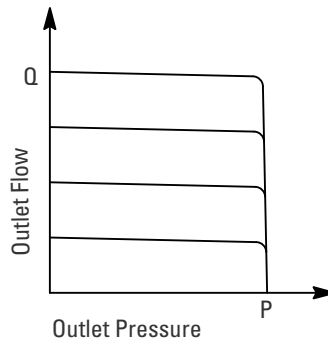

Dynamic Response per SAE J745 (Using Swash Plate Position)

	Response (off stroke)	Recovery (on stroke)	Load Sense Recovery
	msec	msec	msec
AEC028	20	65	70

Control Options

Pressure Compensator

Pressure Compensator Control

The pump will provide a continuously modulated flow to meet changing load demands at a pre-adjusted compensator pressure. At pressures below the compensator setting, the pump will operate at maximum displacement. See model code on page 4 for compensator pressure ranges.

Warning: When adjusting the pressure limiter, install a 0 to 350 bar (0 to 5000 psi) gage in the outlet gage port and limit the pressure setting to the continuous rated pressure for the pump displacement shown on page 6. It is possible to adjust the pressure compensator beyond the rated pressure of the pump. Doing so, may void the warranty of the X20 pump.

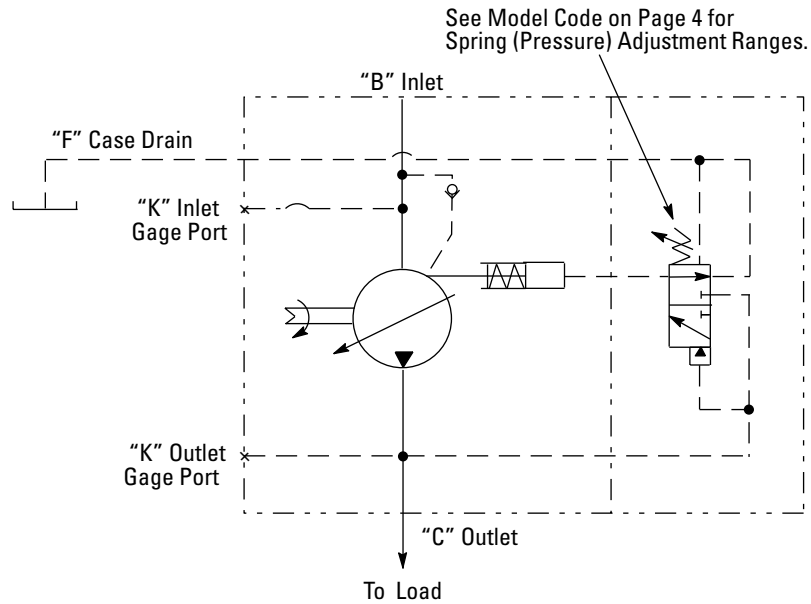

Pressure Limit Settings

The pressure compensator uses two springs to cover the full pressure range of the X20 pumps. The high pressure spring covers the range from 140 bar (2050 psi) to 280 bar (4060 psi). The low pressure spring is adjustable from minimum pressure through 140 bar (2050 psi).

Pressure Cut-off Characteristics of Pressure Compensator Control

@ 49°C (120°F), Static Conditions.

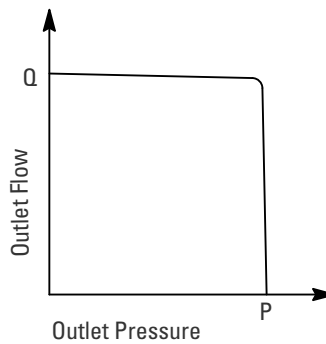

Dynamic Response per SAE J745 (Using Swash Plate Position)

	Response (off stroke)	Recovery (on stroke)
	msec	msec
AEC098	20	65

Overall Efficiency Versus Speed @ 49°C (120°F), Full Flow, and 1.0 bar (0 psi) Inlet

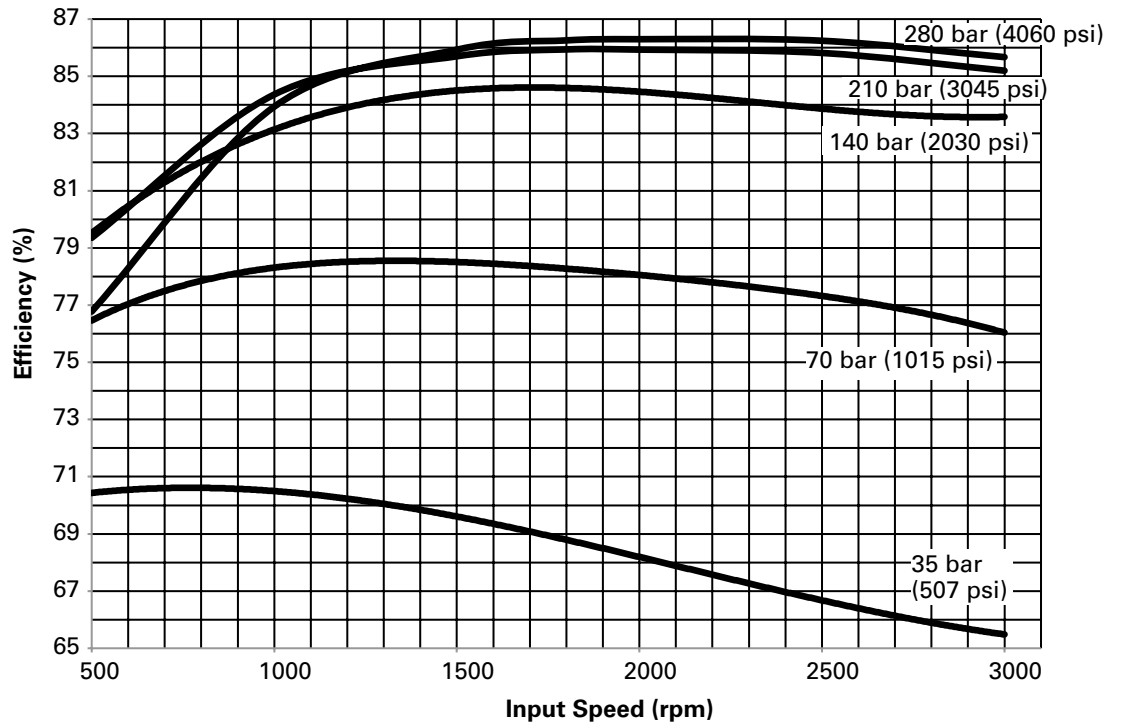

Performance

AEC028

Input Power Versus Speed @ 49°C (120°F), Full Flow, and 1.0 bar (0 psi) Inlet

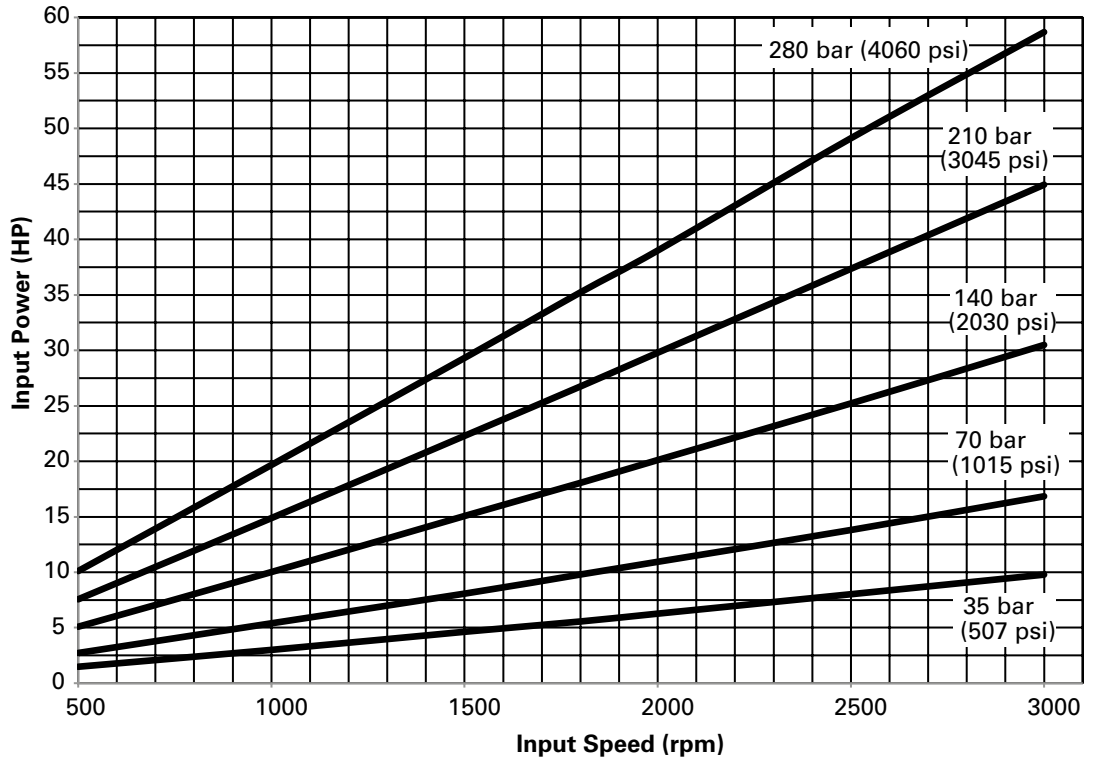

Input Torque Versus Speed @ 49°C (120°F), Full Flow, and 1.0 bar (0 psi) Inlet

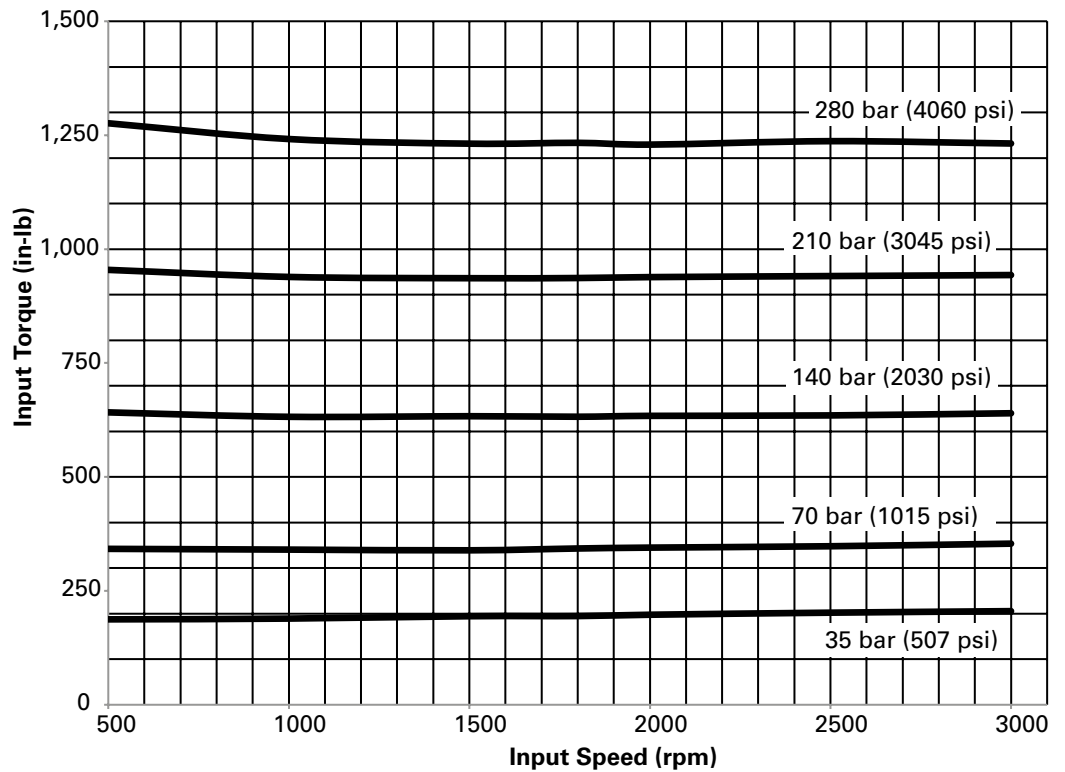

Delivery and Case Flow Versus Speed @ 49°C (120°F)

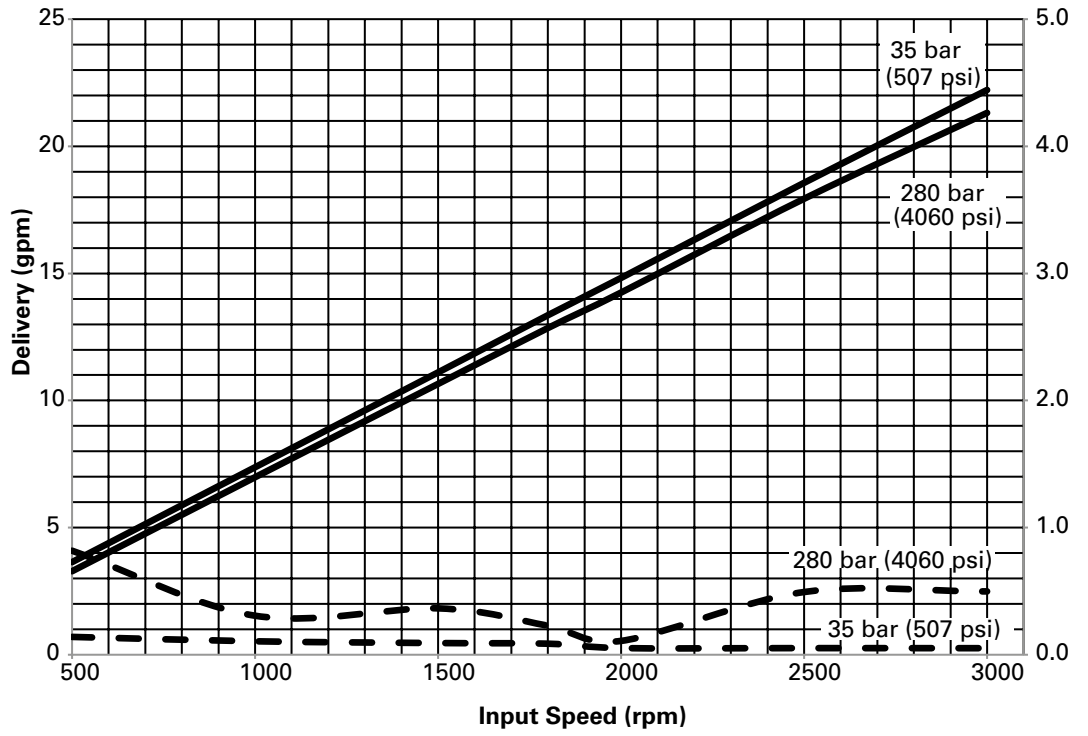

Pump Installation

B-mount / Rear-ported

RH Rotation

B-Mount / Rear Ported

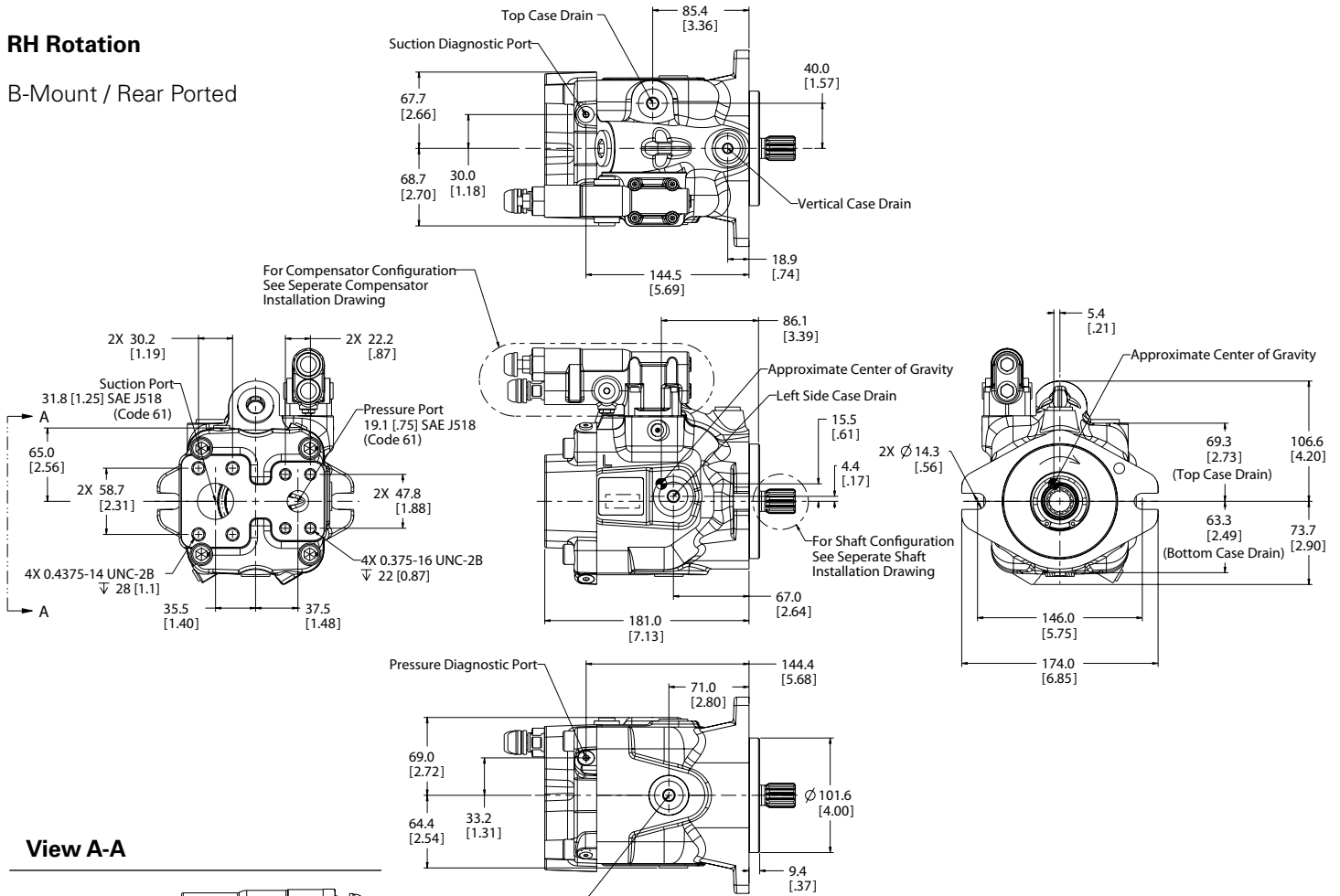

View A-A

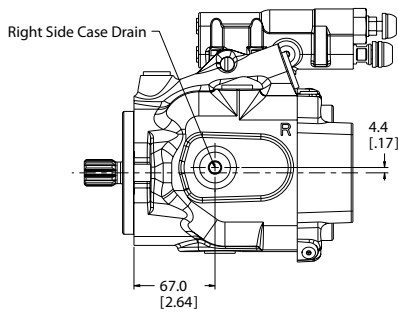

LH Rotation

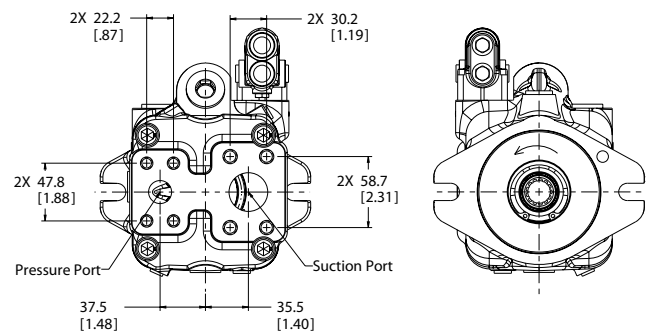

SAE O-Ring Port (RH)

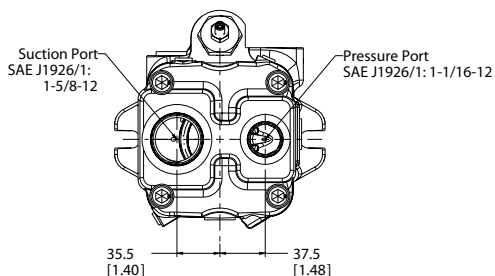

Pump Installation

B-mount / Side-ported

RH Rotation

B-Mount 2 Bolt/ Side Ported

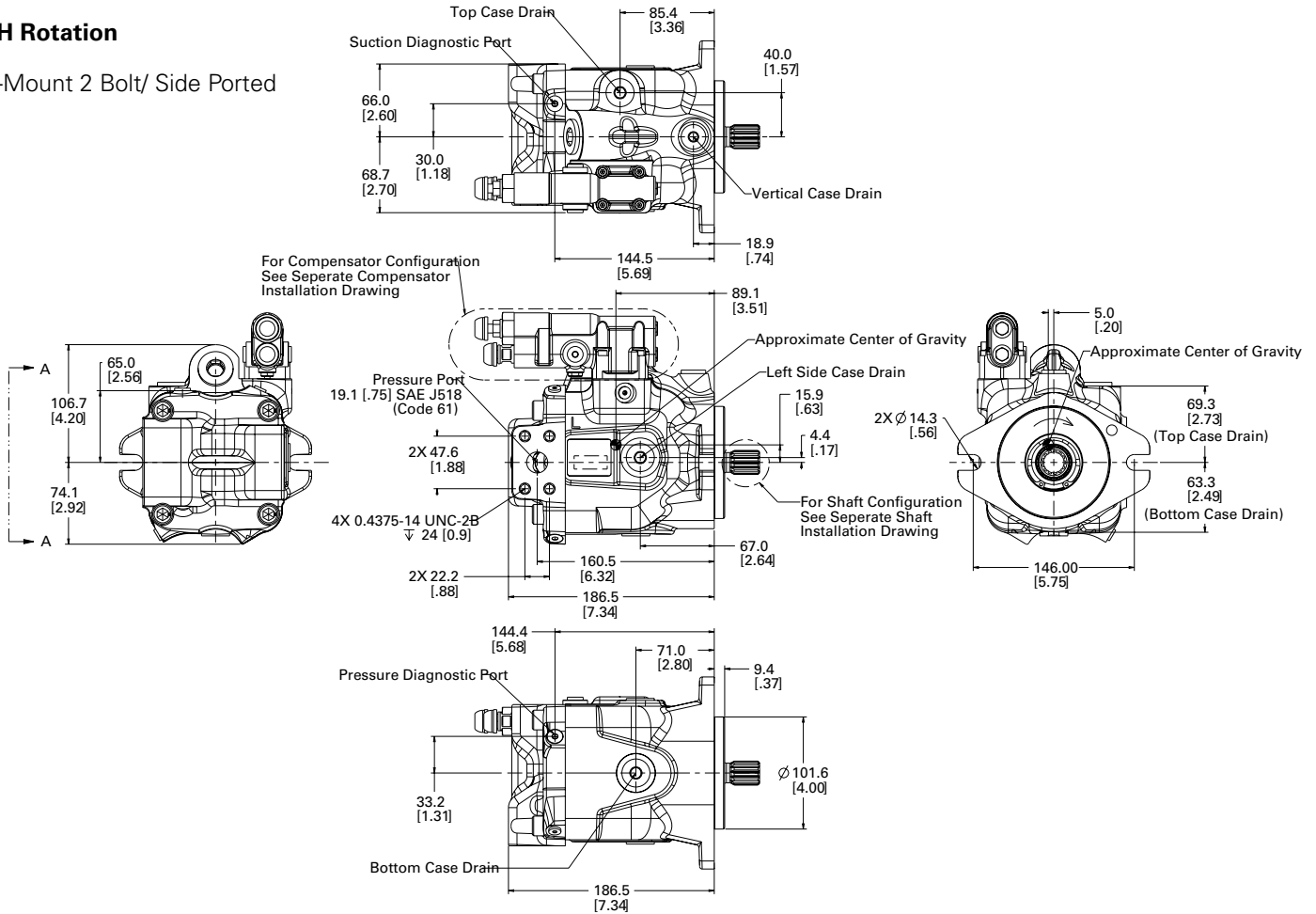

View A-A

LH Rotation

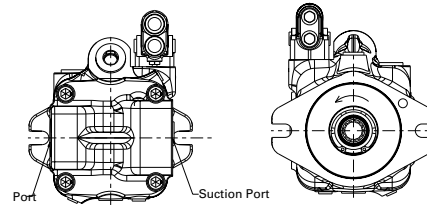
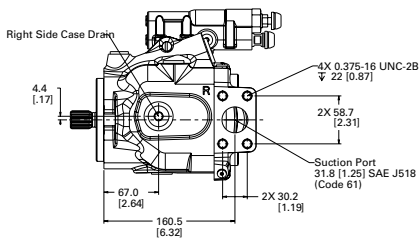

SAE O-Ring Suction Port (RH)

SAE O-Ring Pressure Port (RH)

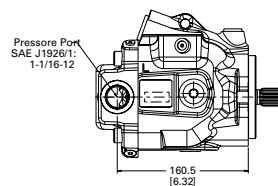
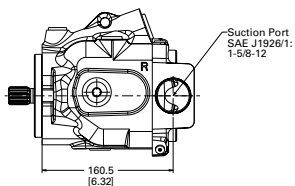

Control Installation

Load Sense and Pressure Compensator

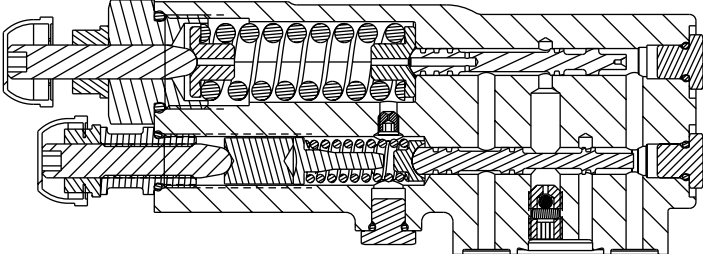
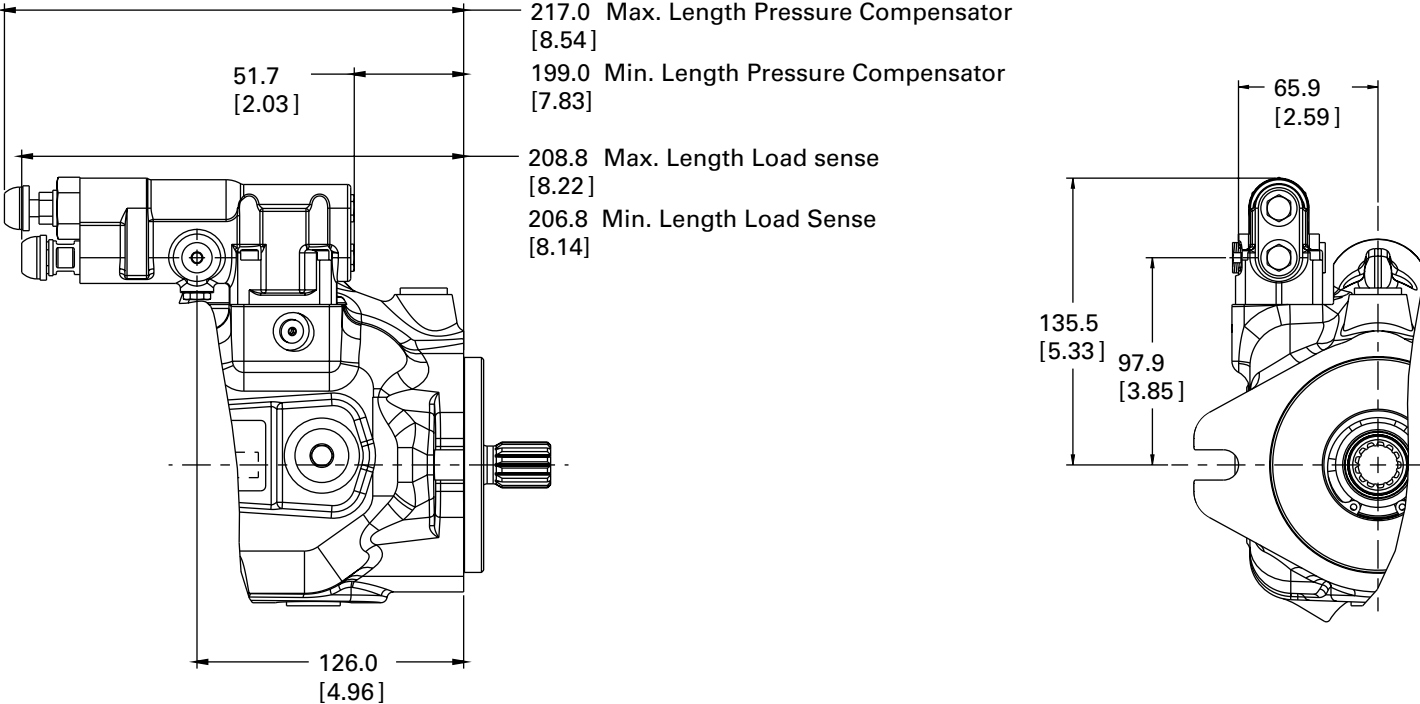

Control Installation

Pressure Compensator

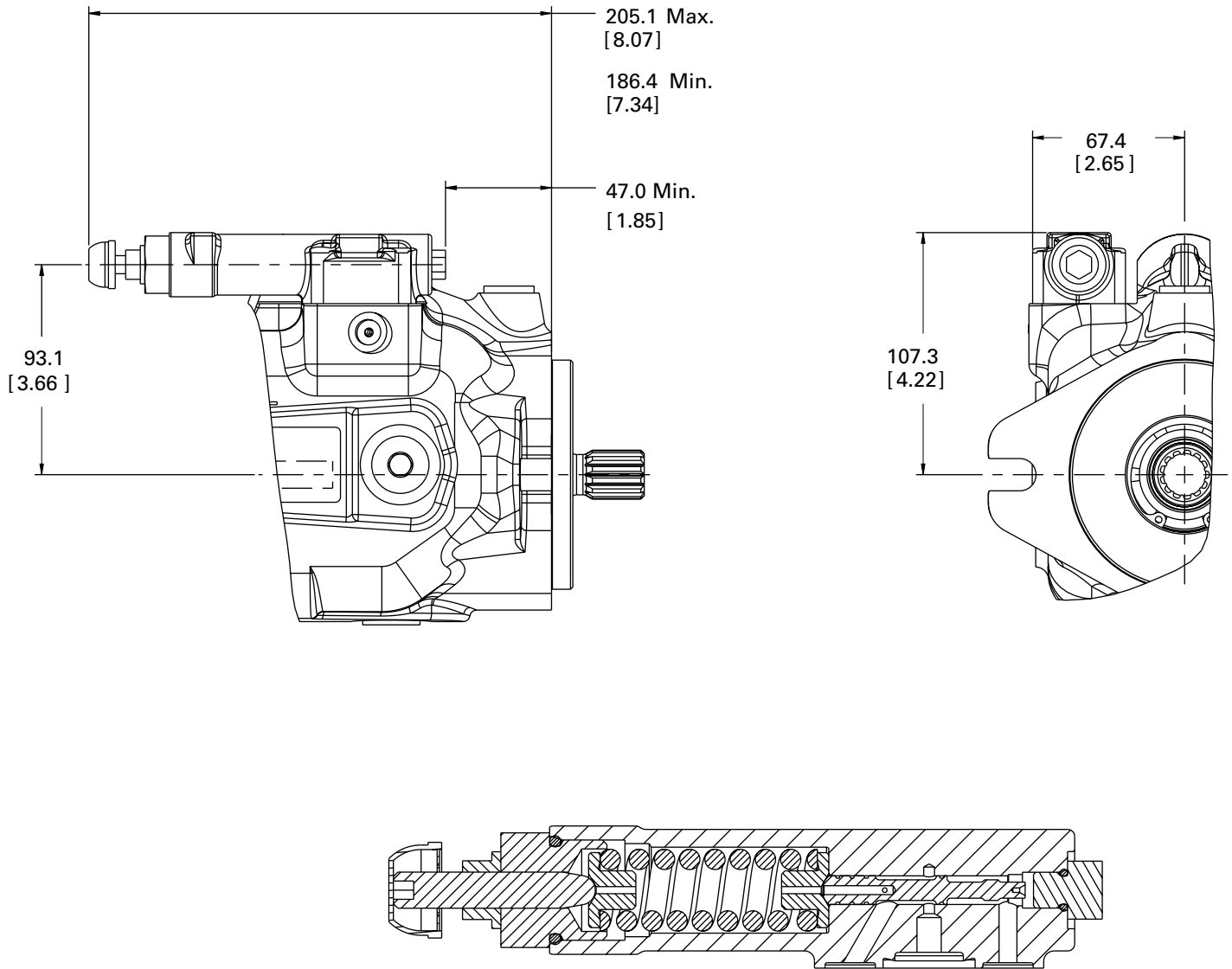

External Manual Stroke Adjustment

Maximum Stroke Limiter

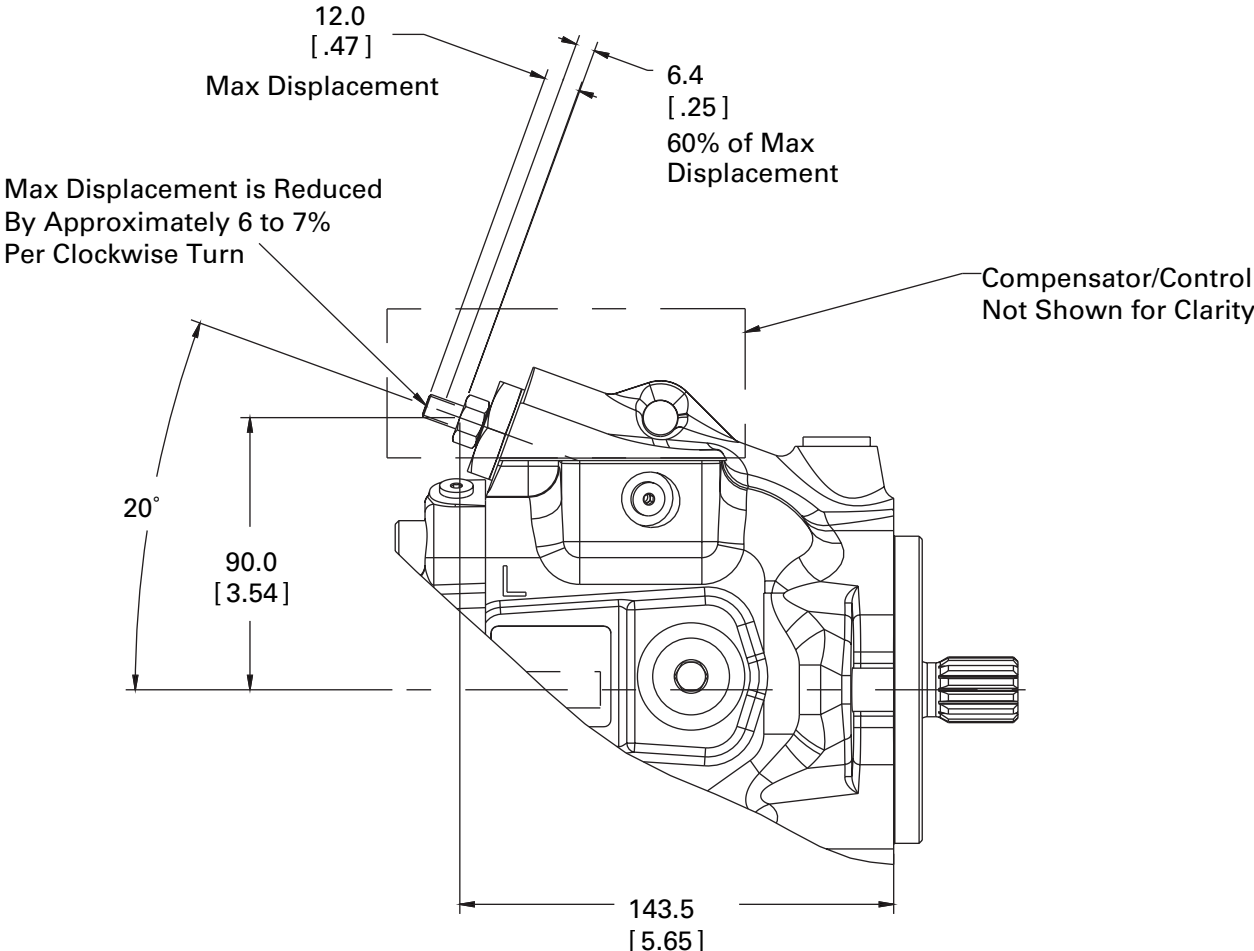

Input Shaft Options

05 Code

Maximum Torque
450 Nm [3980 in-lbf]

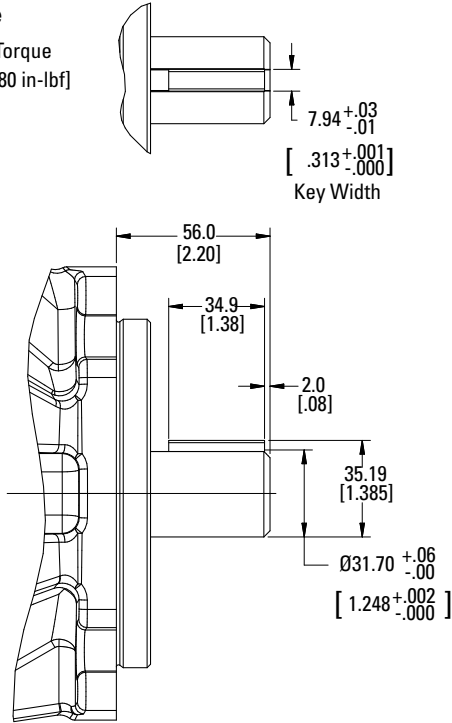

06 Code

Maximum Torque
640 Nm [5660 in-lbf]

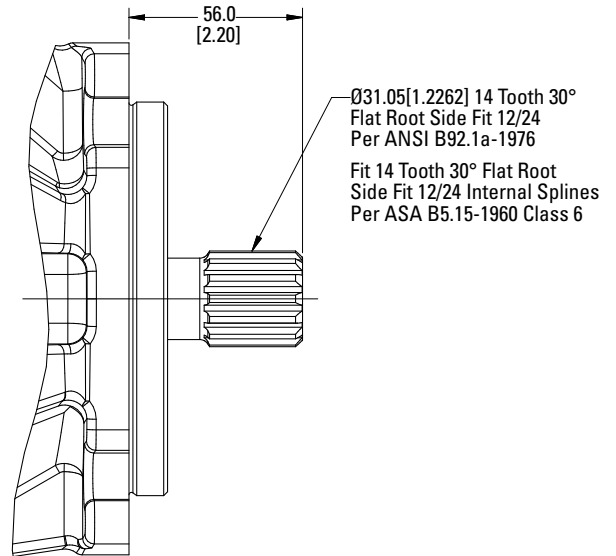

07 Code

Maximum Torque
765 Nm [6770 in-lbf]

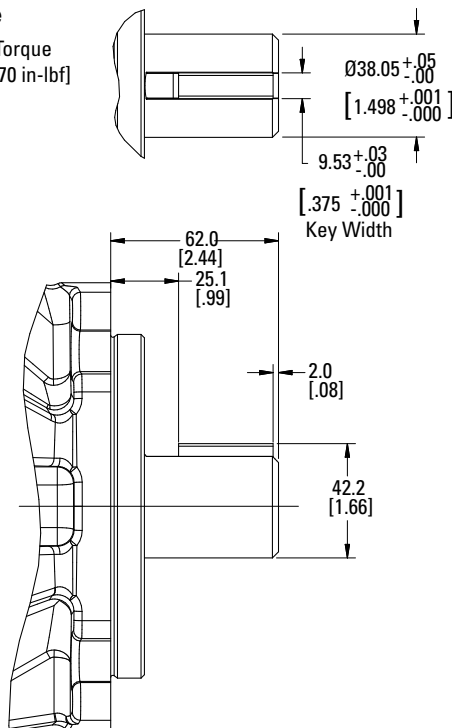

08 Code

Maximum Torque
765 Nm [7665 in-lbf]

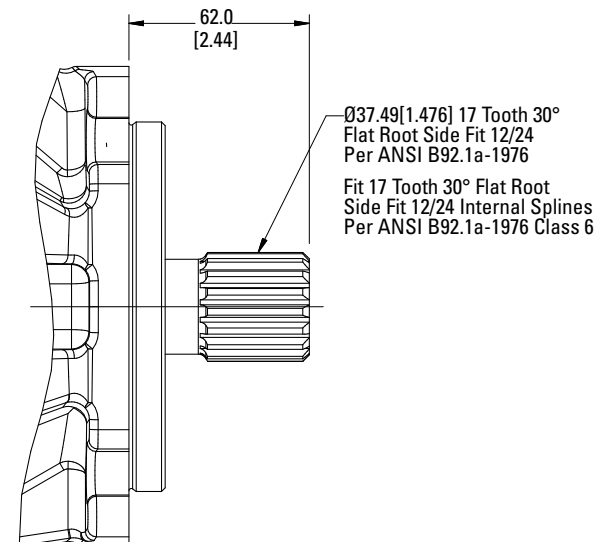

Installation and Start-up

Warning: Care should be taken that mechanical and hydraulic resonances are avoided in the application of the pump. Such resonances can seriously compromise the life and/or safe operation of the pump.

Drive Data

Mounting attitude should be horizontal using the appropriate case drain ports to ensure that the case remains full of fluid at all times. Consult your local Eaton Representative if a different arrangement is required.

Fluid Cleanliness

The X20 Series pumps are rated in anti-wear petroleum fluids with a contamination level of 21/18/13 per ISO 4066. Operation in fluids with levels more contaminated than this is not recommended. Fluids other than petroleum, severe service cycles, or temperature extremes are cause for adjustment of these codes. Please contact your Eaton Representative for specific duty cycle recommendation.

In those cases where geometric tolerances of mounting are critical, or where specific tolerance ranges are required and not specified, consult Eaton Engineering for specific limits.

Direction of shaft rotation, viewed from the prime mover end, must be as indicated in the model designation on the pump – either right hand (clockwise) or left hand (counterclockwise).

Direct coaxial drive through a flexible coupling is recommended. If drives imposing radial shaft loads are considered, please consult your Eaton Representative.

Eaton X20 Series pumps, as with any variable displacement piston pumps, will operate with apparent satisfaction in fluids up to the rating specified here. Experience has shown however, that pump and hydraulic system life is not optimized with high fluid contamination levels (high ISO cleanliness codes).

Proper fluid condition is essential for long and

Start-up Procedure

Make sure the reservoir and circuit are clean and free of dirt/debris prior to filling with hydraulic fluid.

Fill the reservoir with filtered oil and fill to a level sufficient enough to prevent vortexing at the suction connection to pump inlet. It is good practice to clean the system by flushing and filtering, using an external slave pump.

Caution: Before the pump is started, fill the case through the uppermost drain port with hydraulic fluid of the type to be used. The case drain line must be connected directly to the reservoir and must terminate below the oil level.

satisfactory life of hydraulic components and systems. Hydraulic fluid must have the correct balance of cleanliness, materials, and additives for protection against wear of components, elevated viscosity and inclusion of air.

Essential information on the correct methods for treating hydraulic fluid is included in Eaton publication 561 –

Once the pump is started, it should prime within a few seconds. If the pump does not prime, check to make sure that there are no restrictions between the reservoir and the inlet to the pump, and that the pump is being rotated in the proper direction, and that there are no air leaks in the inlet line and connections. Also check to make sure that trapped air can escape at the pump outlet.

After the pump is primed, tighten the loose outlet connections, then operate for five to ten minutes (unloaded) to remove all trapped air from the circuit.

If the reservoir has a sight gage, make sure the fluid is clear – not milky.

“Eaton Guide to Systemic Contamination Control” – available from your local Eaton distributor. In this publication, filtration and cleanliness levels for extending the life of axial piston pumps and other system components are listed. Included is an excellent discussion of the selection of products needed to control fluid condition.

Eaton
Hydraulics Group USA
14615 Lone Oak Road
Eden Prairie, MN 55344
USA
Tel: 952-937-9800
Fax: 952-294-7722
www.eaton.com/hydraulics

Eaton
Hydraulics Group Europe
Route de la Longeraie 7
1110 Morges
Switzerland
Tel: +41 (0) 21 811 4600
Fax: +41 (0) 21 811 4601

Eaton
Hydraulics Group Asia Pacific
Eaton Building
No.7 Lane 280 Linhong Road
Changning District, Shanghai
200335 China
Tel: (+86 21) 5200 0099
Fax: (+86 21) 2230 7240